

SH5050 Instruction Manual

Revision History

| Revision | Release Date | Revisions | Issued By | Approved By |
|----------|--------------|--------------------|-----------|-------------|
| 1.0 | 5/6/25 | Production Release | QW | JAB |
| | | | | |
| | | | | |

Inspired Energy 25440 NW 8th Place, Newberry, FL 32669
 US toll free: 1-888-5-INSPIRE (1-888-546-7747) Tel: 352 472 4855 Fax: 352 472 4859

www.inspired-energy.com

SH5050A/E/U/X



Desktop Dual Bay Smart Charger+Calibrator Instructions for use

The SH5050 is a standalone dual bay desktop smart, standard battery charger with the added ability to recalibrate the fuel gauge on two smart battery packs using a power sharing configuration. It works with all Inspired Energy® brand “S” Series smart standard packs.

What’s in the box?

1. One SH5050 desktop charger/calibrator
2. One 26V 65W DC power supply with universal mains input
3. One mains cable
 - N. American chargers (SH5050A) are packed with a US 3-pin mains cord
 - European chargers (SH5050E) are packed with a European 2-pin mains cord
 - UK chargers (SH5050U) are packed with a UK 3-pin mains cord
 - SH5050X chargers are not packed with a mains cord

Safety:

1. Do not expose the charger or power supply to water or liquids.
2. Do not open the charger or power supply case, no user serviceable parts are inside.
3. Do not cover the fan exhaust or obstruct the airflow, this will cause overheating.
4. Use only the manufacturer’s power supply and observe terminal polarity.
5. Place the charger in a cool spot, away from external heat sources.
6. Caution - during recalibration the charger may become warm.

Using your Charger:

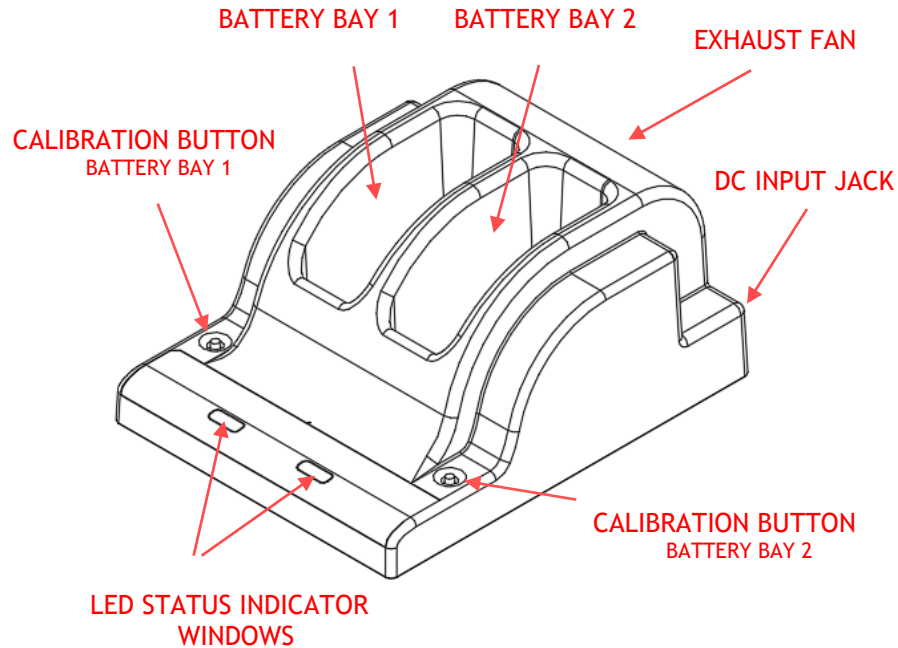

Place the charger on a flat, level surface away from sources of heat and moisture. Plug the DC connector from the power supply into the back of the charger and connect the power supply to the mains AC supply using the cable supplied. The fan turns on, and all LEDs illuminate for two seconds on power up.

Charging:

Place the battery into the battery bay ensuring that the 7-way connector is fully seated. The LEDs in the status window will provide status information and the charger will automatically begin charging.

LED Indication:

The status of the battery is indicated by the LEDs visible in the status window:

| | |
|-------------------|--|
| * Green flashing: | Battery charging |
| ● Green solid: | Battery fully charged |
| * Blue flashing: | Battery in calibration mode |
| ● Blue solid: | Battery fuel gauge calibrated |
| * Red flashing: | Battery fuel gauge needs recalibration |
| ● Red solid: | Error |

Recharge Time:

Different battery packs will require differing recharge times. Battery Bay #1 takes priority in the power sharing configuration, and will receive the majority share of charge current. The times given below are for a full charge from 0% to 100% state of charge using just one bay. They are valid for all variants and custom hybrids of each battery model.

| Battery Chemistry | Battery Model | Recharge Time (hours) | Recalibration Time (hours) |
|-------------------|---------------|-----------------------|----------------------------|
| Li-ion | SJ3008 | 2.5 - 3 | 16 - 17 |

Recalibration Time:

Recalibration consists of a calibration charge, followed by a calibration discharge. Finally the battery is given a regular charge. A calibration cycle will be faster if the battery is fully charged to begin with. Recalibration time is governed by the battery voltage and capacity. Larger batteries, and lower voltage batteries will take longer to recalibrate. Calibration is initiated each time the button is pressed, so it is not recommended to press the recalibration button part way through the recalibration cycle. The built-in fan will turn on only during a discharge of either battery.

What are the SMBus and the SBS?

The Smart Battery System defines the parameters that are stored by an SBS-compliant battery. These parameters include full battery status and fuel gauging information. The System Management Bus is the language by which these parameters are communicated between the battery, the charger and the host device. For full details of the SBS information available from your battery please refer to the battery specification sheet available at www.inspired-energy.com.

How does the charger know what charge to deliver?

The SH5050 charger is capable of sensing and delivering an appropriate charge to all Inspired Energy Li-ion "S" Series standard battery packs. Upon inserting the battery into the charger, the battery communicates to the charger over the SMBus telling the charger what type of cell chemistry it is and what type of charge regime it needs. The SH5050 then configures its output to provide the charge regime requested by the battery. If no SMBus communications are issued from the battery, the charger interrogates the thermistor/resistor I.D. pin on the battery terminal and delivers an appropriate charge. Battery Bay #1 takes priority in the power sharing configuration, and will receive the majority share of charge current

Compatibility:

The SH5050 is fully compatible with all Inspired Energy® brand "S" Series standard battery packs. For optimum results we recommend using only Inspired Energy® brand batteries. For a full list of all compatible Inspired Energy batteries, please visit:

www.inspired-energy.com

SH5050A/E/U/X Specification Summary

| | |
|-----------------------------|---|
| Weight: | 510g / 18oz |
| Height: | 84mm / 3 1/3" |
| Length: | 180mm / 7" |
| Width: | 140mm / 5 1/2" |
| Mating Connector: | 7-blade standard battery connector |
| Communications Compliances: | System Management Bus Rev 1.1, Smart Battery Data Specification Rev 1.1 and Smart Battery Charger Specification Rev 1.1 compliant |
| Power Supply: | 90-260VAC, 26V, 2.5A DC, 119x38x60mm, 500g / 18oz UL listed, CE Compliant |
| Mains Cord: | SH5050A - 110V N. American 3-pin connector SH5050E - 220V European 2-pin connector with ground recess SH5050U - 240V UK 3-pin connector SH5050X - No AC cable supplied |

